



# LINK MOTION HIGH SPEED STRAIGHT SIDE PRESSES

**SM2-220 ~ 440TONS**



**Quality / Productivity / Safety**

**SM2**

**SM2-220 ~ 440TONS**

**LINK MOTION HIGH SPEED STRAIGHT  
SIDE PRESSES**

## Features

### **High Precision & Rigid Structural Design**

*Precise 8 point gibs and high rigidity frame design enables maximum resistance to deflection for precision stamped parts.*

### **Link Motion**

*Increases approach and return slide velocities while decreasing forming and releasing speeds.*

### **Low Forming Speed**

*The slide reaches bottom dead center with a 60% slower velocity than a conventional press. This holds the material in the working portion of the stroke longer, greatly reducing springback of the material, providing better drawing and forming performance, extends tooling life, and decreases noise and vibration.*

### **Unique Dynamic Balancing System**

*During continuous high-speed operation, greatly reduces noise and vibration.*

### **Two-point Slide Connections**

*Extra wide distance between suspension points significantly increases resistance to eccentric loads.*

### **Forced Lubrication System with Fault Monitoring**

*Forced recirculating lubrication reduces heat generation and wear on guide surfaces.*

### **TouchScreen Monitor**

*Automatically monitors and displays possible fault conditions, allowing for simple operation and maintenance.*

### **Extremely Small Total Clearance**

*Total clearance is less than JIS Class 1 standards*



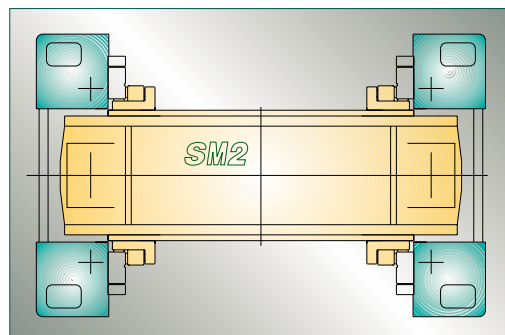
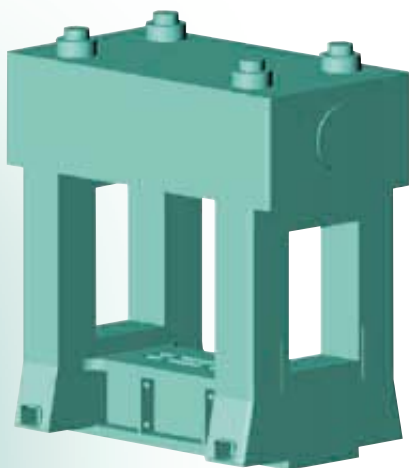

**High Rigidity Straight Side Frame  
Extra-wide 8-point Gibs**

- Four piece frame secured by hydraulically stretched tie-rods and nuts.
- Welded, annealed, and stress relieved slide, bolster and frame designed to reduce deflection to less than 0.00087 in/ft.
- Extra wide 8-point gibs provide greater surface contact area assuring the accuracy and rigidity necessary for high precision parts.

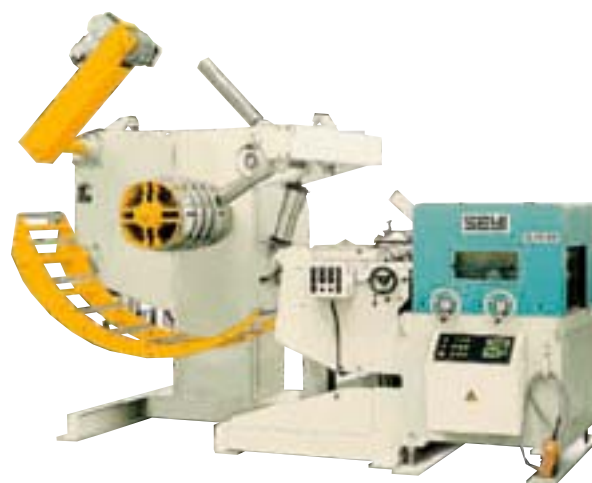

**Available with Quality Peripherals**

- Compact 3-in-1 NC Servo feeder/straightener/decoiler allows for high production rates.

Model		SLF2-40	SLF2-50	SLF2-60
Material Width	in	15.74	19.68	23.62
Material Thickness	in	0.02~0.18	0.02~0.18	0.02~0.18
Material Weight	lbs	6600	6600	6600



### Capacity curve

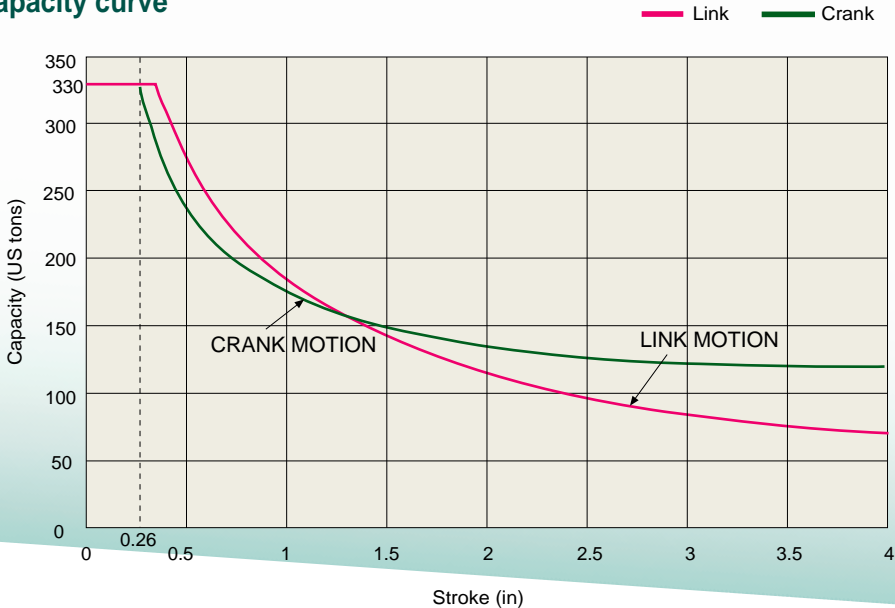

- The slide velocity is reduced during the working portion of the stroke, which leads to significant reductions in vibration, impact on parts being formed and the overheating of the dies.
- Longer die life and extended maintenance intervals.
- During drawing applications, the flywheel energy is efficiently utilized leading to lowered production time requirements and increased variety of forming capabilities.

### Dynamic Balancing System

- The SM2's unique Dynamic Balancing System drastically reduces vibration and noise during high-speed operation.
- With similar forming speeds, the SM2 achieves a productivity increase of over 40% when compared to a standard crank press.

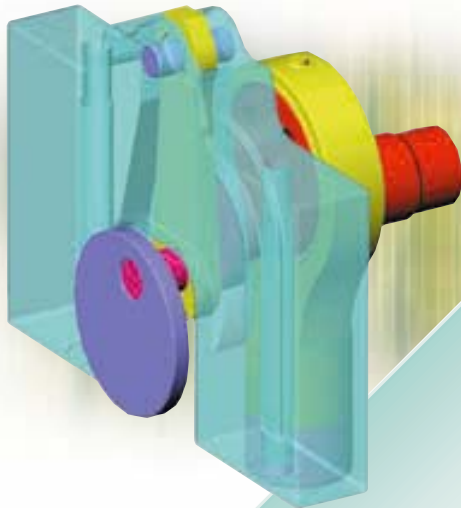

### Progressive Stamping Benefits

- Used under similar production requirements, a single SM2 press can replace two standard straight side presses, reducing overhead costs in energy, labor, and required floor space.

## Drive System Layout

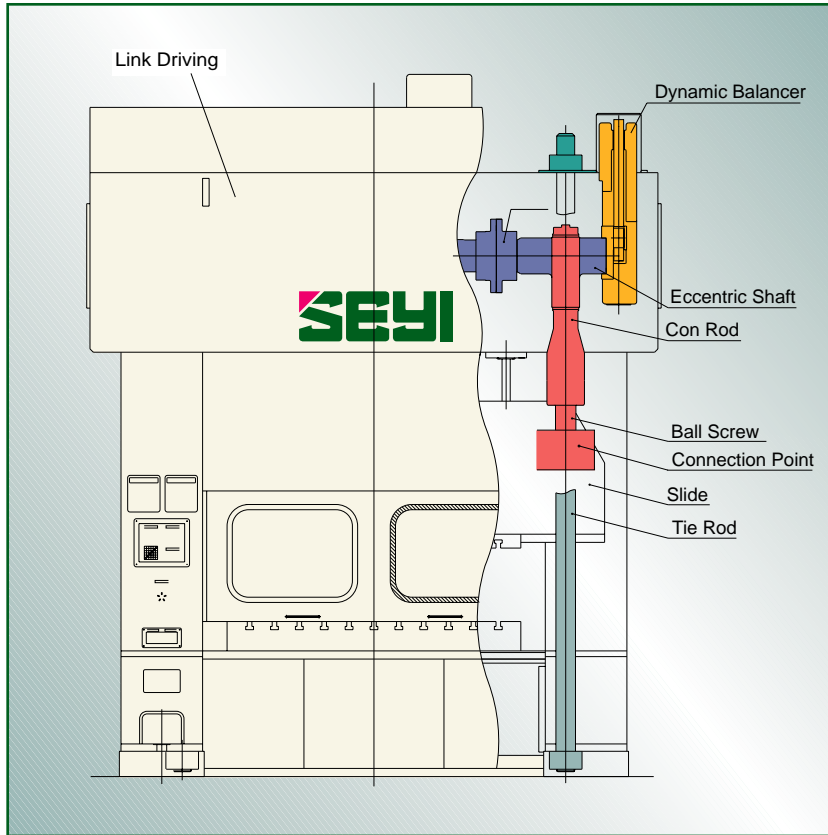

## Link Motion versus Crank Motion

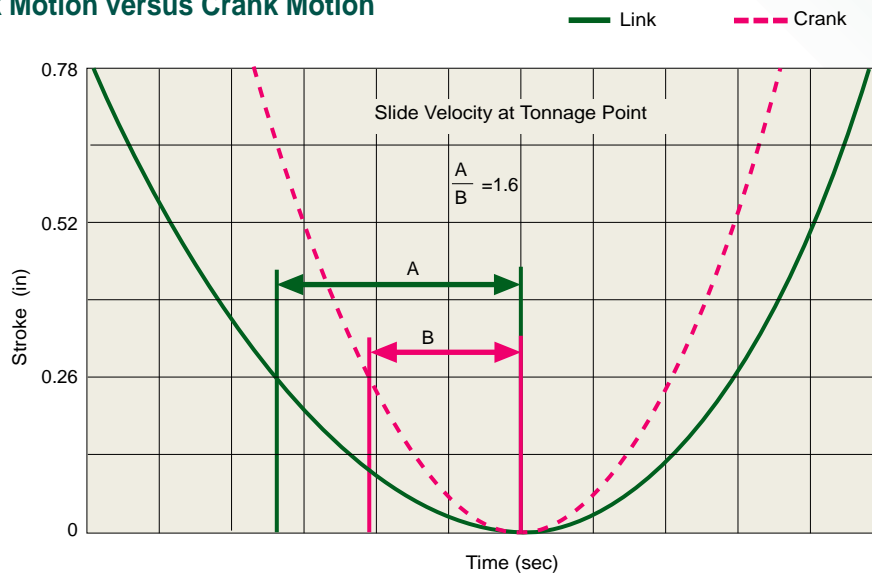



**Specification**

Model		SM2-220	SM2-330	SM2-440
Capacity	US tons	220	330	440
Stroke Length	in	7.87	7.87	7.87
Strokes per Minute	spm	50 ~ 120	40 ~ 100	30 ~ 80
Tonnage Rating Point	in	0.26	0.26	0.26
Die Height	in	17.72	21.65	25.59
Slide Adjustment	in	3.94	3.94	3.94
Slide Area	1	59.06 x 35.43	70.87 x 39.37	82.68 x 43.31
	2	70.87 x 35.43	82.68 x 39.37	94.49 x 43.31
	3	82.68 x 35.43	94.49 x 39.37	106.30 x 43.31
Bolster Area	1	59.06 x 39.37	70.87 x 43.31	82.68 x 47.24
	2	70.87 x 39.37	82.68 x 43.31	94.49 x 47.24
	3	82.68 x 39.37	94.49 x 43.31	106.30 x 47.24
Bolster Thickness	in	7.09	7.87	10.63
Floor to Bolster Height	in	39.37	45.28	49.21
Upper Die Weight	lbs	2200	3300	6600
Main Motor	HP x P	40 x 4	50 x 4	60 x 4
Window Opening	in	27.56 x 9.84	31.50 x 9.84	35.43 x 9.84
Machine Height	in	175.20	196.85	216.54

**Standard Attachments**

1. Variable speed main motor
2. Flywheel brake and main motor FWD/REV control
3. Combination wet clutch/brake
4. Motorized slide adjustment
5. Hydraulic overload protection
6. Automatic, recirculating lubrication system
7. Air counter balance system
8. PanelView touch screen monitor
9. OSHA, ANSI and CSA compliant dual PLC control system

10. 8 channels of die protection
11. 8 channels of PLS
12. Built in part and batch counters
13. Mis-feed detector
14. Air ejector and outlet
15. Floor mounted control console
16. Portable operator T-stand
17. Front and rear interlocked safety doors
18. Die area lighting
19. Maintenance tool kit
20. Isolation mounts

**Optional Attachments**

1. Quick die change system
2. Light curtains
3. Tonnage monitor
4. Custom control configurations

**EX : SM2-300**

**CAPACITY-STROKE CURVE DIAGRAM**

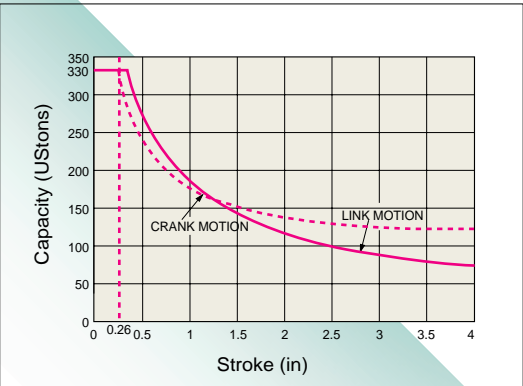

**VELOCITY-STROKE CURVE DIAGRAM**

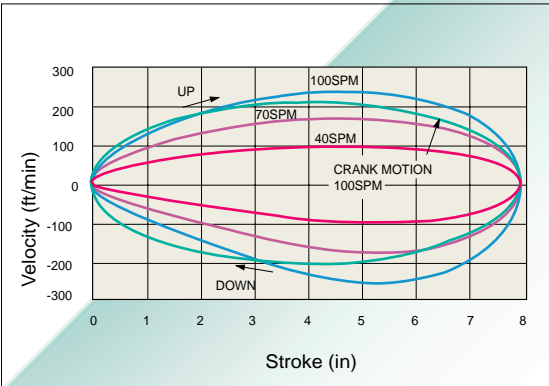



**SEYI-AMERICA, INC.**

203 Lemon Creek Dr., Unit A Walnut, CA 91789.  
TEL: 909.839.1151 FAX: 909.839.1150